

**Sears**

**owners  
manual**

**MODEL NO.  
47.297730**

**CAUTION:**  
Read **SAFETY**  
**RULES** and  
**INSTRUCTIONS**  
carefully



**Sears**

**3 H.P. CHAIN DRIVE  
TILLER**

- **Assembly**
- **Operating**
- **Maintenance**
- **Repair Parts**

**SEARS, ROEBUCK AND CO., Chicago, Ill. 60684 U.S.A.**  
**and SIMPSONS-SEARS LIMITED, Toronto, Canada**

## **FULL ONE YEAR WARRANTY**

For one year from the date of purchase, Sears will repair any defect in material or workmanship in this TILLER at no charge.

If the TILLER is used for commercial or rental purposes, this warranty applies for only thirty days from the date of purchase.

Warranty service is available by contacting the nearest Sears store or Service Center throughout the United States.

This warranty gives you specific legal rights, and you may also have other rights which vary from state to state.

Sears, Roebuck and Co.  
Sears Tower  
BSC 41-3  
Chicago, IL 60684

# **IMPORTANT**

It is suggested that this manual be read in its entirety before attempting to assemble or operate. Keep this manual in a safe place for future reference and for ordering replacement parts.

This unit is shipped WITHOUT GASOLINE or OIL. After assembly, see operating section of this manual for proper fuel and amount.

Your tiller is a precision piece of power equipment, not a play thing. Therefore exercise extreme caution at all times.

## **SAFE OPERATION PRACTICES FOR TILLERS**

- Read the Operating and Service Owner's Manual carefully. Be thoroughly familiar with the controls and the proper use of the equipment.
- Never allow children to operate a power tiller. Only persons well acquainted with these rules of safe operation should be allowed to use your tiller.
- Keep the area of operation clear of all persons, particularly small children and pets.
- Do not operate equipment when barefoot or wearing open sandals. Always wear substantial footwear.
- Do not wear loose fitting clothing that could get caught on the tiller.
- Do not start the engine unless the shift lever is in the neutral (N) position.
- Do not stand in front of the tiller while starting the engine.
- Do not place feet and hands on or near the tines when starting the engine or while the engine is running.
- Do not leave the tiller unattended with the engine running.
- Do not walk in front of the tiller while the engine is running.
- 11. Do not fill gasoline tank while engine is running. Spilling gasoline on hot engine may cause a fire or explosion.
- 12. Do not run the engine while indoors. Exhaust gases are deadly poisonous.
- 13. Be careful not to touch the muffler after the engine has been running, it is hot.
- 14. Before any maintenance work is performed or adjustments are made, remove the spark plug wire and ground it on the engine block for added safety.
- 15. Use caution when tilling near buildings and fences, rotating tines can cause damage or injury.
- 16. Before attempting to remove rocks, bricks and other objects from tines, stop the engine and be sure the tines have stopped completely. Disconnect the spark plug wire and ground to prevent accidental starting.
- 17. Check the tine and engine mounting bolts at frequent intervals for proper tightness.
- 18. Keep all nuts, bolts and screws tight to be sure the equipment is in safe working condition.
- 19. Never store the equipment with gasoline in the tank inside of a building where fumes may reach an open flame or spark. Allow the engine to cool before storing in any enclosure.

### **NOTE**

A spark arrest muffler is available as an accessory part. The part number is listed in the parts section of this manual. Check muffler legal requirements in your area.

# INDEX

|                               |   |                                |            |
|-------------------------------|---|--------------------------------|------------|
| Warranty.....                 | 2 | Operation.....                 | 10         |
| Safe Operation Practices..... | 3 | Maintenance.....               | 12         |
| Introduction.....             | 4 | Tiller Repair Parts.....       | 16         |
| Hardware Identification.....  | 5 | Tiller Accessories.....        | 19         |
| Tiller Identification.....    | 6 | Engine Repair Parts.....       | 21         |
| Assembly Instructions.....    | 7 | How To Order Repair Parts..... | Back Cover |
| Engine Preparation.....       | 9 |                                |            |

## INTRODUCTION

This Product has been designed, engineered and manufactured to give you the best possible dependability and performance.

Should you experience any problem you cannot easily remedy, please contact your nearest Sears, or Simpson-Sears Service Department. They have well qualified, competent trained technicians and the proper tools to service or repair this unit.

### PRE-ASSEMBLY



The right and left side of your tiller is determined from operator's position.

Before any step is undertaken, the instructions for that step should be read through.

#### TOOLS REQUIRED: See Figure 1

1. (1) 1/2" Socket, open or box wrench.
2. (2) 9/16" Socket, open or box wrench.
3. (1) 1/4" Flat Screwdriver.

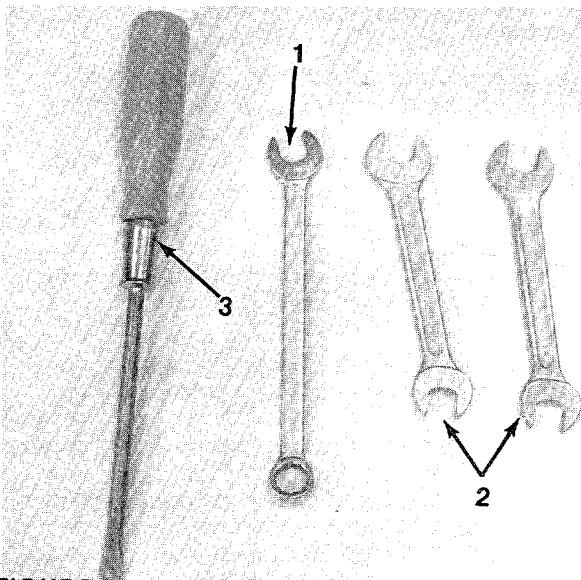


FIGURE 1.

#### MATERIALS REQUIRED:

1. Funnel (for gas and oil - **NOTE: DO NOT MIX**)
2. SAE 30 heavy duty detergent oil. 1 1/4 pints.
3. Gas (regular)
4. Cleaning rag

#### PARTS IN CARTON: See figures 2 and 3.

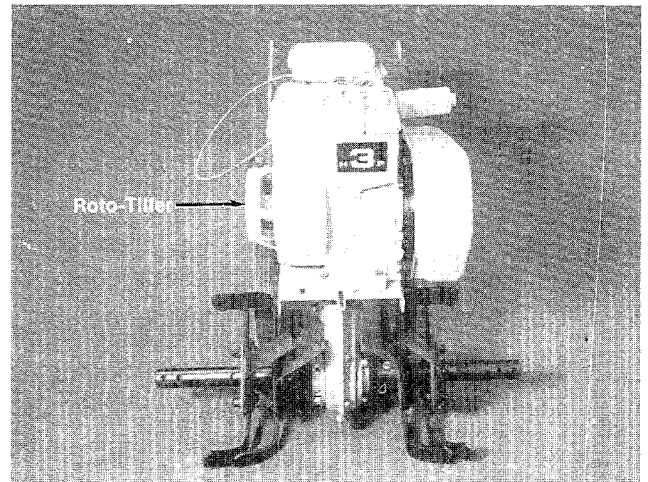


FIGURE 2.

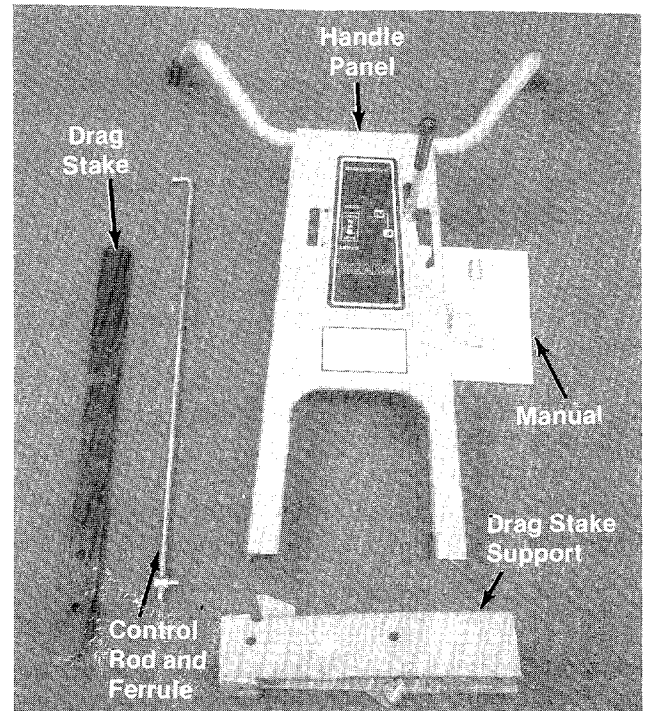


FIGURE 3.

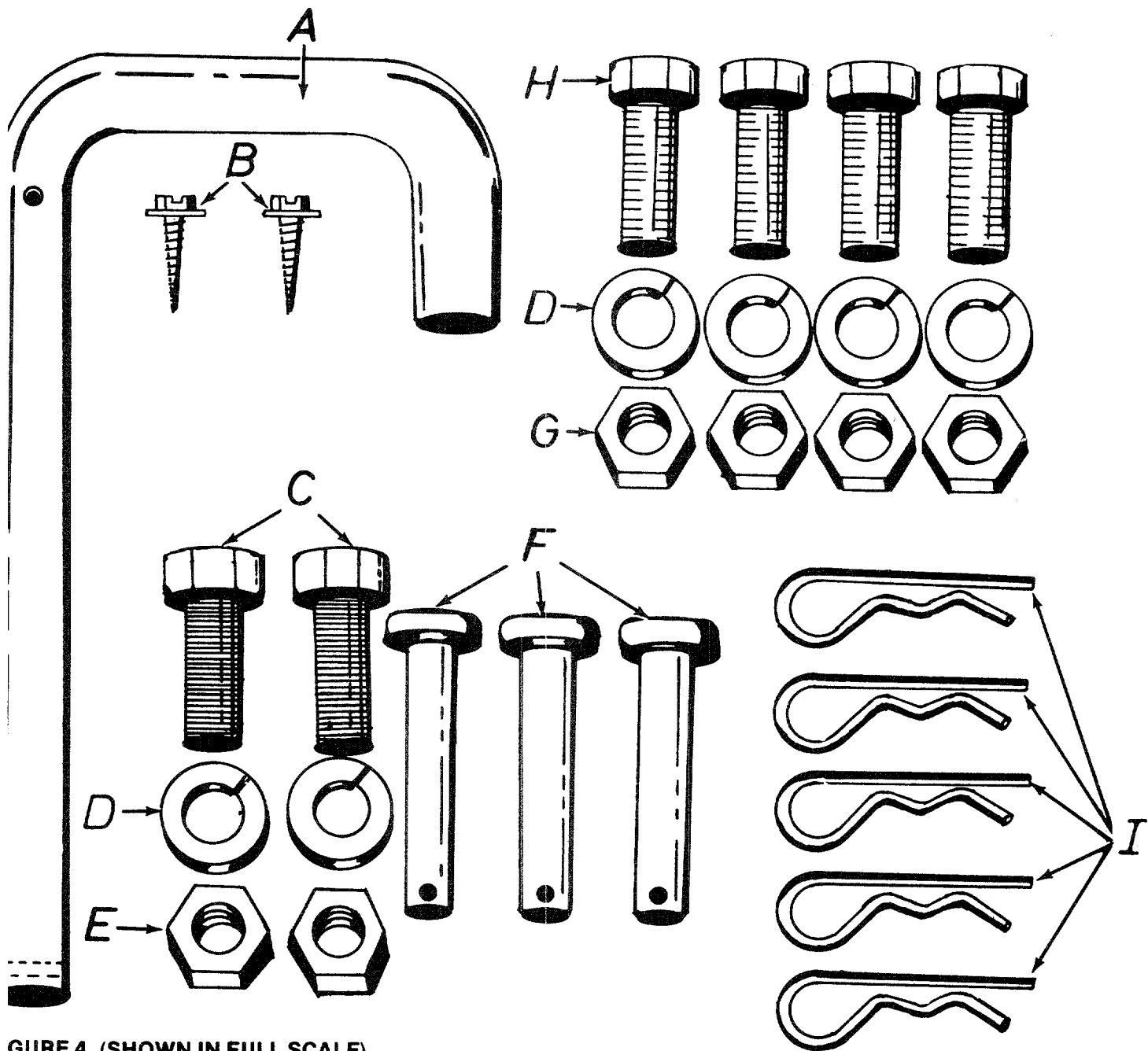


FIGURE 4. (SHOWN IN FULL SCALE)



**NOTE**

THE LETTERS LISTED BELOW WILL BE REFERRED TO THROUGHOUT THE FOLLOWING TEXT FOR EASIER HARDWARE IDENTIFICATION.

**LIST OF CONTENTS IN HARDWARE PACK:**

- A (1) "U"-Clevis Pin 1/2" Dia.
- B (2) Self Tapping Screws #8 x .62"
- C (2) Hex Screws 3/8-24 x 1.00"
- D (6) Lockwasher 3/8" Screw

- E (2) Hex Nut 3/8-24 Thread
- F (3) Clevis Pins
- G (4) Hex Nuts 3/8-16 Thread
- H (4) Hex Screws 3/8-16 x 1.00"
- I (5) Hair Pin Cotter

# TILLER IDENTIFICATION

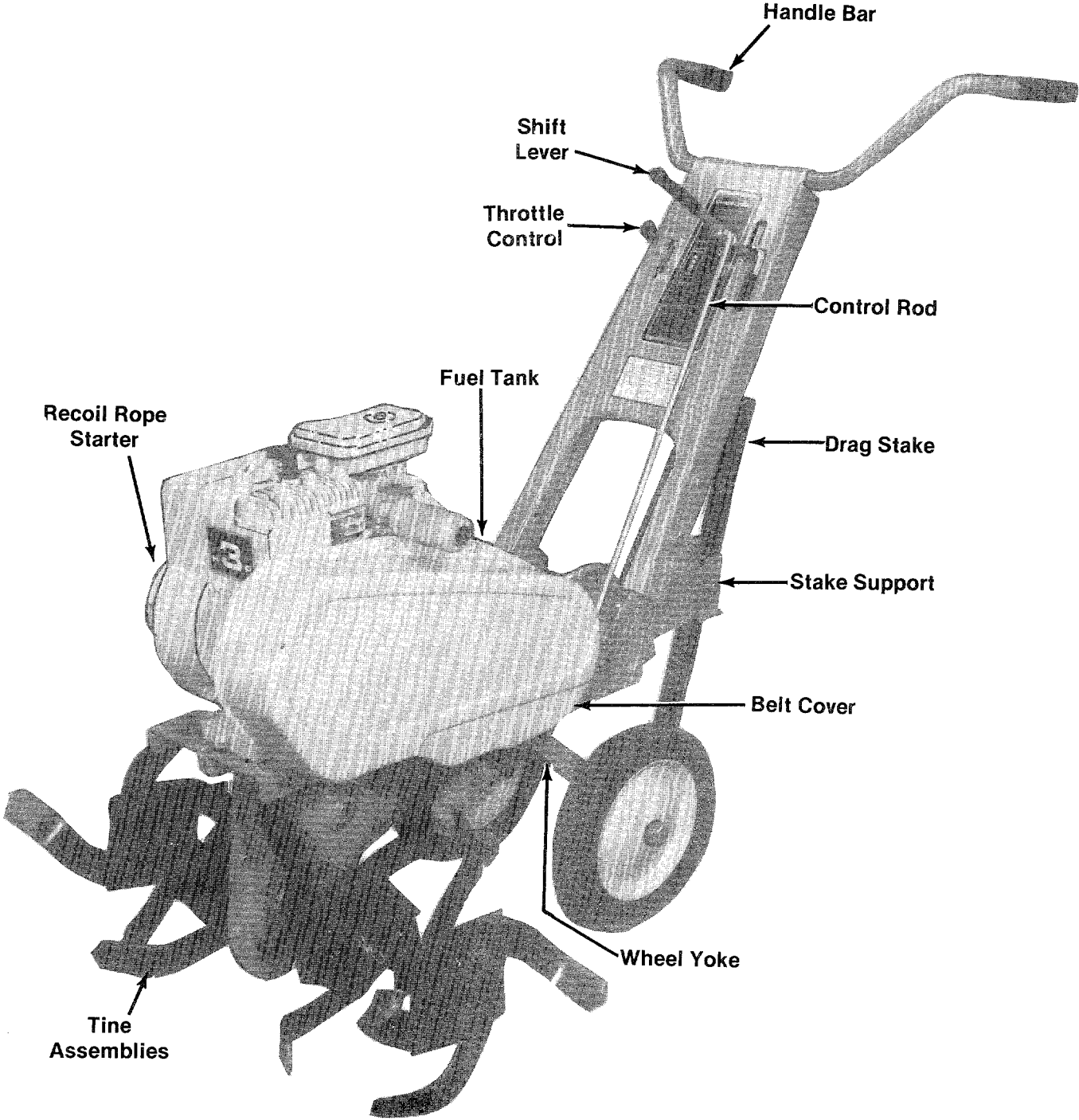


FIGURE 5.

# ASSEMBLY INSTRUCTIONS

## 1. Handle Panel Attachment.

For shipping purposes, the handle mounting brackets are pivoted forward. With a 9/16" wrench loosen the hex bolt holding the handle mount brackets. See figure 6.

Pull handle mount brackets back so that the bottom hole in bracket lines up with forward hole in chassis. See figure 5, 6 and 7.

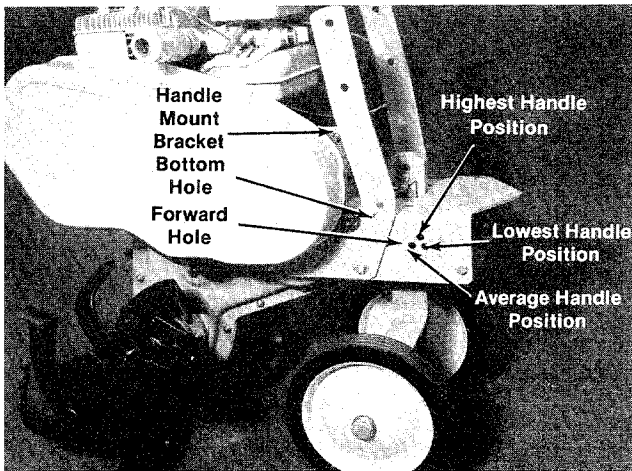


FIGURE 6.

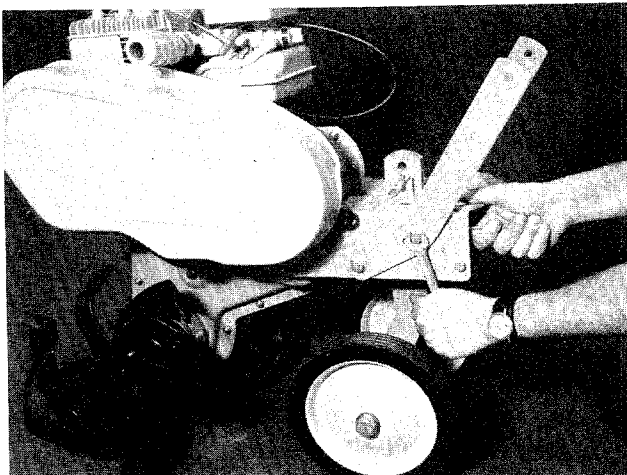


FIGURE 7.

Secure handle mount brackets with hex bolt (C), lockwasher (D) and hex nut (E). See hardware, page 4.

The handle panel is attached by sliding it down over the handle brackets on the chassis and installing four hex bolts in the lower holes of the handle panel. Place bolts through the handle panel; head to the outside. See figure 6.



Do not tighten until all four bolts are in place.

Four hex bolts (H), lockwashers (D) and hex nuts (G) will be found in the hardware pack. See figure 8.

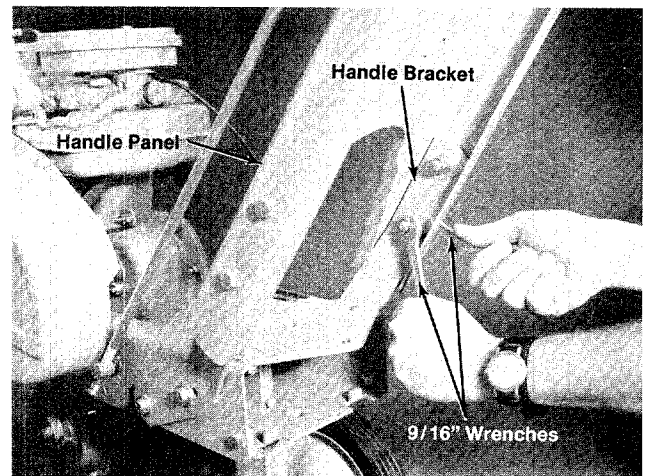


FIGURE 8.

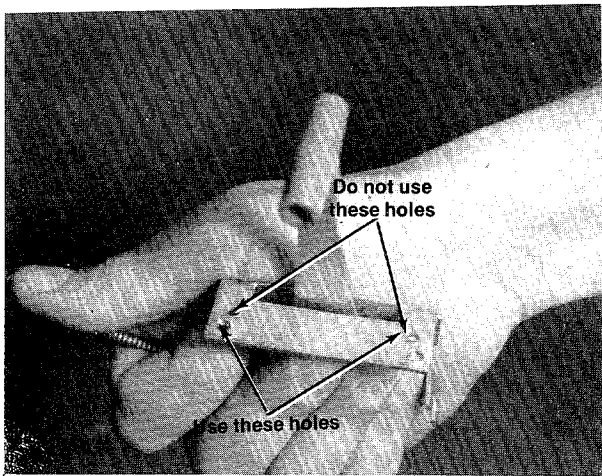
## 2. Throttle Control Lever.



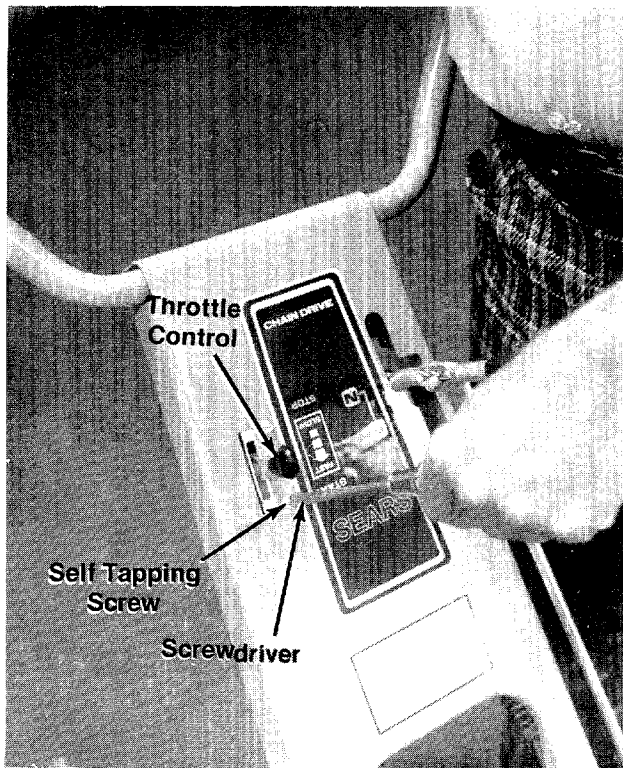
The throttle control has four holes in the lever bracket. The holes on the outside edge are to be used for mounting on this unit. See figure 9.

Place throttle control lever up through the handle panel and secure with two self tapping screws (B), using a 1/4" flat screwdriver. See figure 10.





**FIGURE 9.**



**FIGURE 10.**

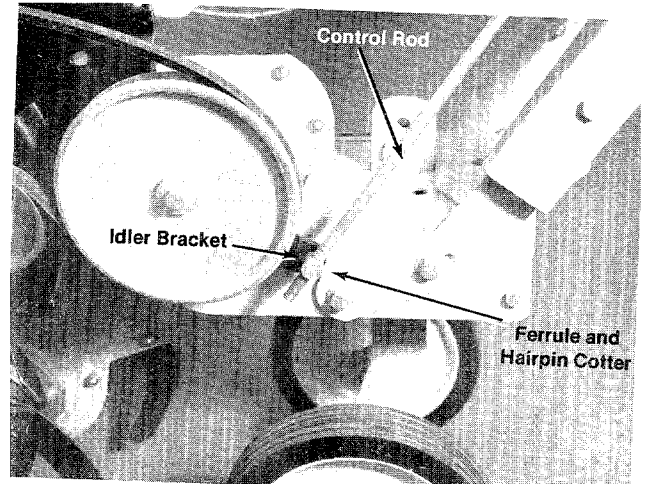
**3. Clutch Control Rod.**

The control rod comes from the factory with the ferrule preadjusted. (See figure 11.) Place ferrule in idler bracket. Secure with hair pin cotter.



Figure 11 has the belt guard removed for clarity, it is not necessary to remove for control rod assembly.

Place the shift lever (located on handle panel) in neutral (N) position. Place other end of control rod in shift lever and secure with hair pin cotter.



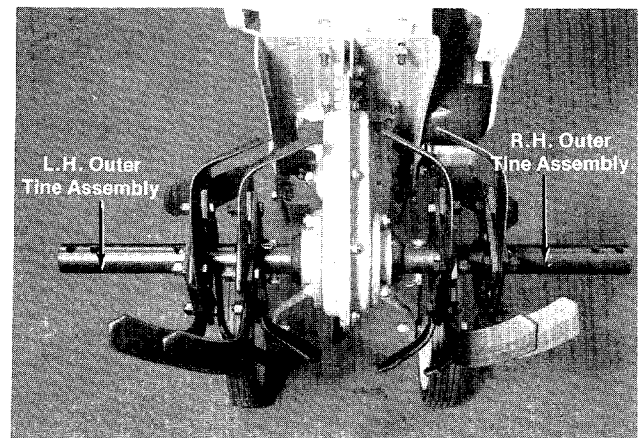
**FIGURE 11.**

**4. Tine Attachment.**

- a. The outer tines have been reversed on the tine shaft for shipping purposes. See figure 12.

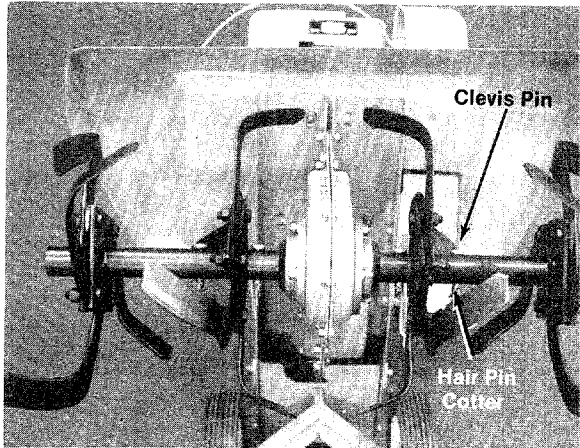
Remove outer tines from the tine shaft and reinstall with the tine hub facing inward as illustrated in figure 13. Secure tines with clevis pins (F) and hair pin cotters (I).

- b. The inner tine assemblies have been installed at the factory and in their correct operating position and do not require changing.
- c. See tine adjustment for information on changing width of tilling path, page 11.



**FIGURE 12.**

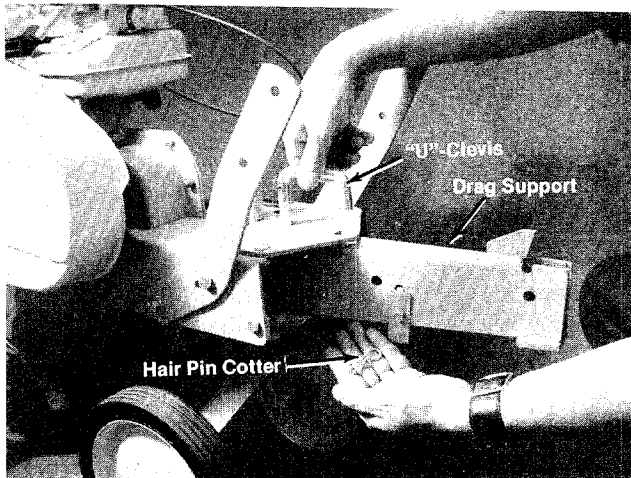




**FIGURE 13.**

### 5. Drag Stake Support Attachment.

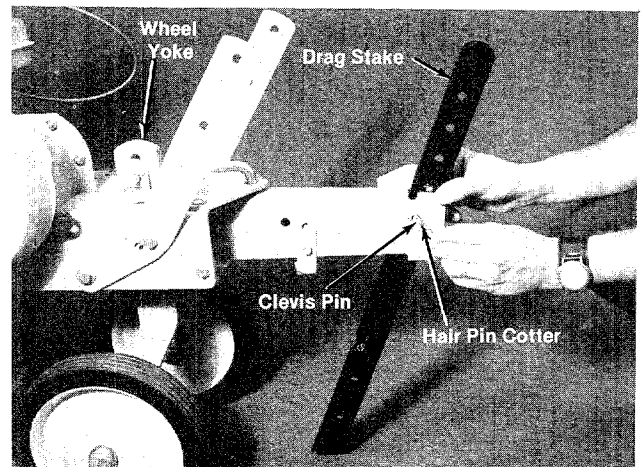
Slide the drag stake support into the chassis and secure with "U" clevis (A) and hair pin cotter (I). See figure 14.



**FIGURE 14.**

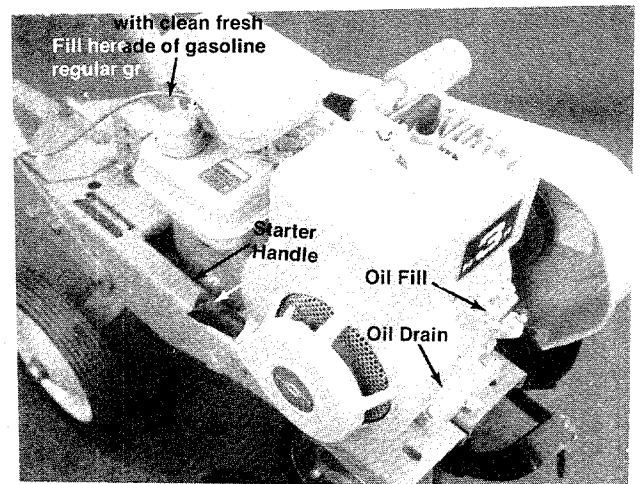
### 6. Drag Stake Attachment.

Slide the drag stake into the drag stake support depth and secure with clevis pin (F) and hair pin cotter (I). See figure 15.



**FIGURE 15.**

## ENGINE PREPARATION



**FIGURE 16.**

1. Before starting, fill crankcase with 1¼ pints of SAE 30 heavy duty detergent oil or to top of filler neck. Be sure that the engine is level. See figure 16.
2. Change oil after first 2 hours of operation and every 25 hours thereafter. Check oil every 8 operating hours.
3. Fill fuel tank with clean fresh regular grade of gasoline.

# OPERATION

## TO START ENGINE:

1. CAUTION: BE SURE NO ONE IS STANDING IN FRONT OF THE TILLER WHILE THE ENGINE IS RUNNING OR BEING STARTED.
2. Place the shift lever in the neutral (N) position. See figure 17.

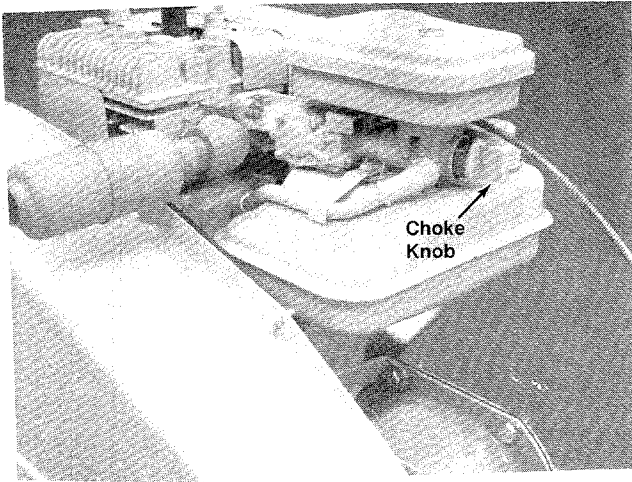


FIGURE 17.

3. Choke Engine. Pull choke knob out to choke engine. See figure 17. Once the engine starts, push in the choke knob.

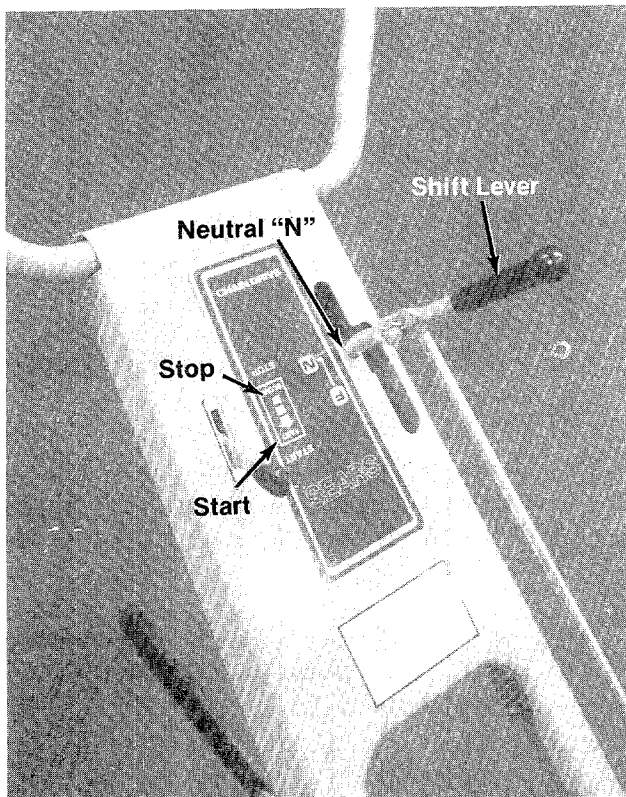


FIGURE 18.

4. Move the throttle control lever forward to START POSITION. See figure 18.
5. Stand at side of the tiller, grasp the starter handle and pull out rapidly. Return it slowly to the engine. Repeat as necessary.



If engine is warm, start with the control in the "START" position. Choking may not be necessary. See figure 18.



FIGURE 19.

6. Move the throttle control to SLOW when transporting the tiller. When the tiller is being moved to or from the garden, the depth should be pivoted forward until it engages the drag stake retainer clip. The machine may be moved under its own power, without seriously damaging grass areas as long as it is allowed to move freely. If the operator holds back, it will start to dig.

## TILLING

1. Adjust drag stake by removing clevis pin and hair pin cotter, changing stake position, then replacing hair pin cotter and clevis pin. See figure 15.
  - A. Lowering the drag stake will slow the tiller and make it till deeper.
  - B. Raising the drag stake will allow the tiller to move faster and till shallower.

- C. For normal tilling, set drag stake at the fifth or sixth hole from the top.
- 2. Adjust wheel yoke by removing clevis pin and hair pin cotter, changing wheel yoke height, and replacing clevis pin. See figure 15.
  - A. Raising the wheel yoke will allow the tiller to till deeper.
  - B. Lowering the wheel yoke will allow the tiller to till shallower.
  - C. For normal tilling set wheel height at the second or third hole from the top.

## TILLING HINTS

Soil conditions are important for proper tilling.

The tines will not readily penetrate dry, hard soil. This may contribute to excessive bounce and difficult handling of the tiller. Hard soil should be moistened prior to tilling.

Extremely wet soil will cause soil to ball up or clump.

When tilling in the Fall, all vines and long grass should be removed. This will prevent vines from wrapping around the tine shaft which slows tilling operation.

The best method will be determined by the soil condition. In some soils, the desired depth is obtained the first time over the garden. In other soils, the desired depth is obtained by going over the garden two or three times. In the latter case, the drag stake should be lowered before each succeeding pass over the garden, and passes should be made across the length and width of the garden alternately. Rocks which are turned up should be removed from the garden area.

**Handle Pressure:** Further control of tilling depth and travel speed can be obtained by variation of pressure on the handles.

When using the drag stake a downward pressure on the handles will increase the working depth and reduce the forward speed. An upward pressure on the handles will reduce the working depth and increase the forward speed. The type of soil and working conditions will determine the actual setting of the drag stake and the handle pressure required.

## CONTROLS

**LOCATION AND USE:** See figure 18.

- 1. Shift Lever: The shift lever is located on the left hand side of the handle panel. Left hand is determined from the operator's position, standing behind the tiller.
  - A. Forward (F)—Move the lever to the left and down (Forward) to set unit in motion.
  - B. Neutral (N)—Move lever to center detent.

- 2. Throttle Control: The throttle control lever is located on the right hand side of handle panel.
  - A. Stop—Pull lever back (upward) to stop the unit.
  - B. Start—Push lever forward (down) to start unit.

## CULTIVATING

For cultivating, a two to three inch depth is desirable. Setting the wheels and drag stake so that the wheels are about two inches above the ground, while the tiller is resting on the tines and drag stake, will allow the machine to work at cultivating depth. The throttle should be set to control forward movement to a slow walking speed. With standard tines, the working width of the machine is 26 inches. See figure 20.

Tilling width can be increased from 26 inches to 28 inches by removing the clevis pin and hair pin cotter and sliding the outer tines out one (1) inch, and replacing the clevis pin and hair pin cotter. See figure 21.

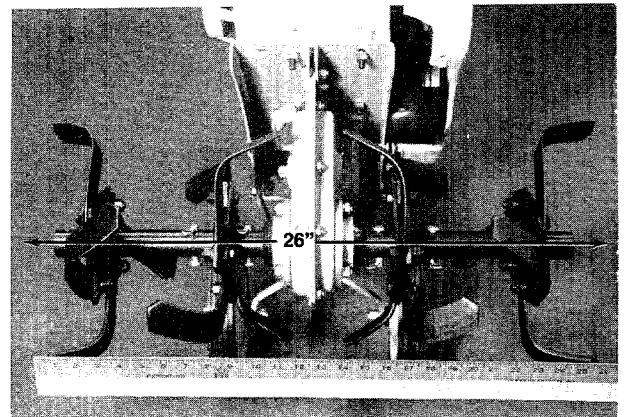


FIGURE 20.

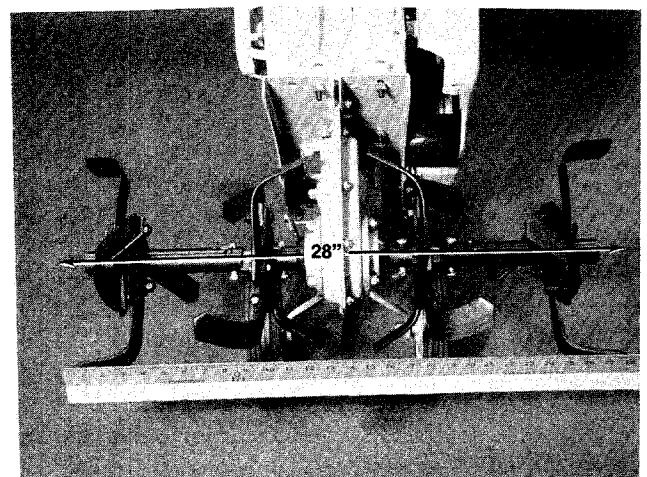
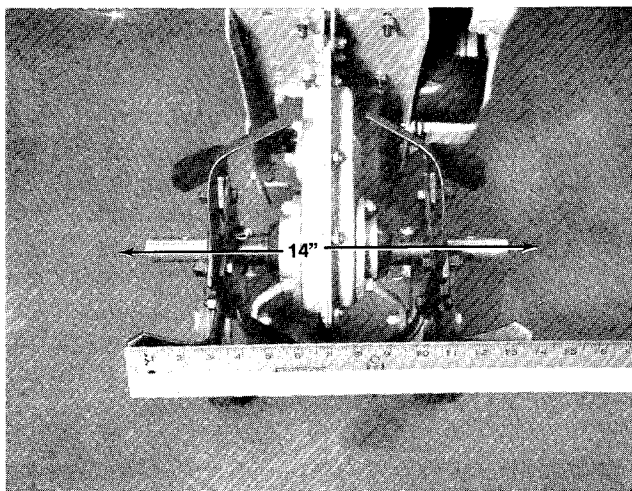


FIGURE 21.

For cultivation, this may be reduced to 14 inches by removing the outer tines. See figure 22.



**FIGURE 22.**

In laying out plant rows be sure to allow enough width (14" to 15") to permit cultivation between the rows.

In growing corn or similar crops, check-row planting will permit cross cultivation and practically eliminate hand hoeing. The tiller has many uses other than tilling and cultivating a garden. One of these is the preparation of lawn area for seeding. The tiller will prepare a deep seed bed which will be free of hard untilled spots, allowing a better stand of grass to grow. The tiller is very useful for loosening hard soil for excavation with a shovel. Your tiller may be used for mixing compost in the pile, or for mixing it with the soil in your garden. This should be done after the soil has been broken to the full working depth. The compost should be worked in to a depth of six to eight inches. This may be done by working the length of the garden, and then by mixing separate passes across its width. The addition of decayed organic matter will substantially increase the fertility of your garden. For proper decaying action, fertilizer should be applied and worked in with the mulch materials. The breaking up of the leaves and straw and the mixing of it with the several inches of soil cause the soil to hold moisture longer and allow proper aeration of the plant root system. This also retards the growth of weeds.

The U.S. Department of Agriculture and various state and local agencies offer published booklets and expert advice on all phases of gardening. They should be consulted regarding soil information, planting dates, and the most satisfactory varieties of crop for your particular area.

## MAINTENANCE

### BELT REPLACEMENT:

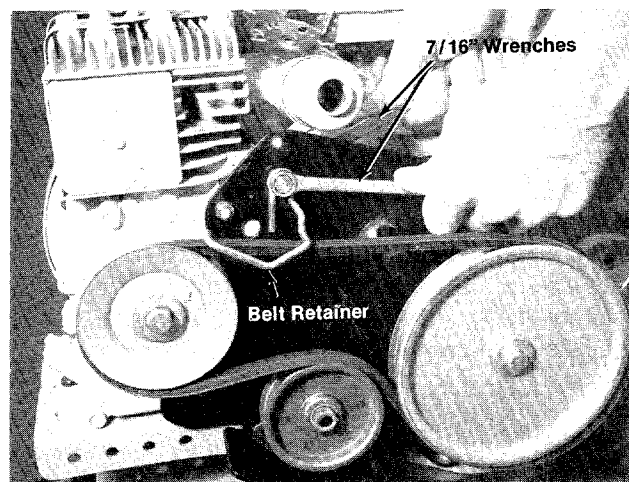
If belt replacement is required order belt by part number from your nearest Sears Service Center.

**FORWARD DRIVE BELT - Part No. 754-0154**  
1/2" x 37" long

Your tiller has been engineered with the above belt and should not be replaced with an off-the-shelf belt. The above belt is of special material (Kevlar Tensile).

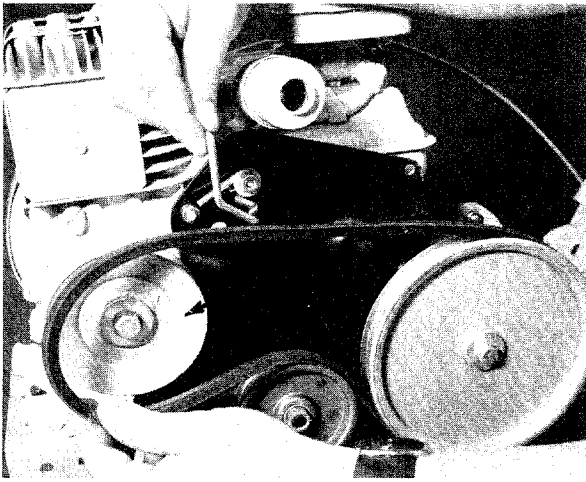
Removing and replacing the FORWARD DRIVE BELT.

1. Remove the belt guard, by removing four (4) hex self tapping screws.
2. Loosen, do not remove the hex screw and nut holding the belt retainer with two 7/16" wrenches. See figure 23.



**FIGURE 23.**

3. Lift the belt retainer up and slip the belt off the engine pulley, flat idler and transmission pulley. See figure 24.



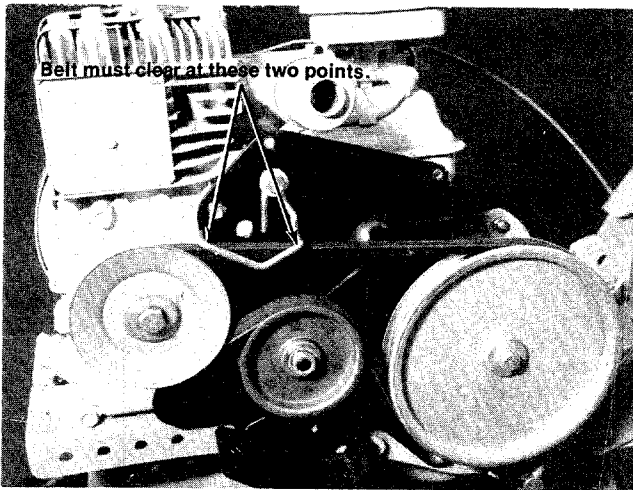
**FIGURE 24.**

Reassemble the new belt with the "V" side of belt to the inside. Assemble in reverse order of steps 1, 2 and 3.



Upon tightening the hex bolt and nut on belt retainer, read the following steps.

1. Place the shift lever in the forward (F) position to tighten the belt.
2. Pivot the belt retainer down into position, make sure the belt does not touch the retainer. See figure 25.



**FIGURE 25.**

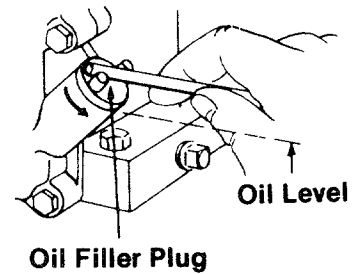
## CARE AND MAINTENANCE:

### Transmission:

The transmission is pre-lubricated and sealed at the factory. It requires no additional lubrication unless the transmission is disassembled. To fill with grease, lay the left half of the chain case on its side, add 14 ounces of Plastilube #1 grease and assemble the right half to it. This grease can be from your nearest Sears Service Center. (Order Part No. 737-0133.)

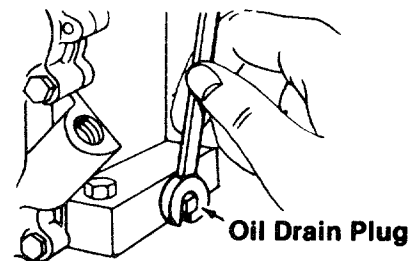
### Engine:

1. You **MUST CHANGE THE OIL** in the crankcase after the first two hours of operation of your new engine and after each 25 hours of use thereafter to ensure proper lubrication of internal parts for trouble free operation and to prevent costly repair due to excessive wear. (Take care to remove dirt around filler plug.) Be sure oil level is maintained full to point of overflowing. See figure 26.



**FIGURE 26.**

To change oil remove drain plug (figure 27) and tip the tiller forward while engine is warm. Replace drain plug. Remove oil filler cap and refill with new oil of proper grade. Replace filler cap.



**FIGURE 27.**

2. Always use the **PROPER FUEL** in your engine. Use only a good grade of fresh, clean, regular gasoline. Do not use gasoline that has been sitting for a long period of time. Stale gasoline may cause engine to run poorly or not at all.



3. Keep your engine **CLEAN**. Wipe off all spilled fuel and oil. Keep the engine clean of foreign matter and be sure the cooling fins on the cylinder are kept clean to permit proper air circulation. You must **REMEMBER** that this is an air cooled engine and free flow of air is essential to proper engine performance and life.
4. You must **SERVICE YOUR AIR CLEANER**. The air cleaner prevents damaging dirt, dust, etc. from entering the carburetor and being forced into the engine and is important to engine life and performance.

To remove air cleaner:

- A. Remove screw.
- B. Remove air cleaner carefully to prevent dirt from entering carburetor.
- C. Take air cleaner apart.
- D. Wash element in detergent and solution by squeezing similar to a sponge.
- E. Wrap foam in cloth and squeeze dry.
- F. Coat element with two tablespoons of engine oil, squeeze to distribute and remove excess oil. See figure 28.
- G. Wipe air cleaner body with same solution to remove excess oil.
- H. Reassemble (see figure 28) by inserting element into body and snapping cover into place, fasten to carburetor with screw.

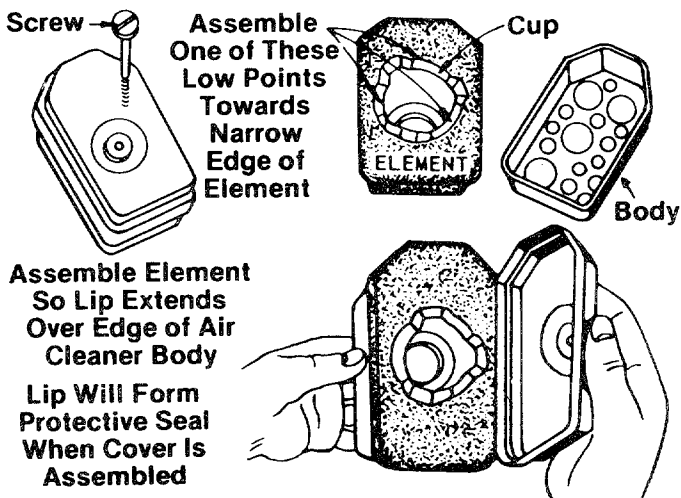


FIGURE 28.

**NEVER RUN YOUR ENGINE WITHOUT AIR CLEANER COMPLETELY ASSEMBLED.**

### CARBURETOR ADJUSTMENTS

Minor carburetor adjustment may be required to compensate for differences in fuel, temperature, altitude and load.



Adjust carburetor with fuel tank half full of regular grade gasoline.

**Initial Adjustment: See figure 29.**

Close needle valve (turn clockwise) then open  $1\frac{1}{2}$  turns (turn counterclockwise). This initial adjustment will permit the engine to be started and warmed up before making final adjustment.

**Final Adjustment: See figure 29.**

With engine running at normal operating speed (approximately 3000 RPM without load) close the needle valve (turn clockwise) until engine starts to lose speed (lean mixture). Then slowly open needle valve (turn counterclockwise), past the point of smoothest operation, until engine just begins to run unevenly. This mixture should be rich enough for best performance under load. Hold throttle in idling position. Turn idle speed adjusting screw until fast idle is obtained (1750 RPM). Test the engine under full load. If engine tends to stall or die out, it usually indicates that the mixture is slightly lean and it may be necessary to open the needle valve slightly to provide a richer mixture. This richer mixture may cause a slight unevenness in idling.

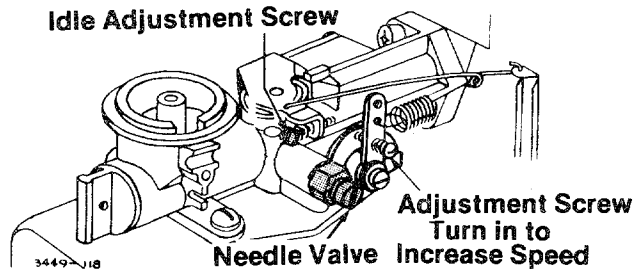


FIGURE 29.

### CHOKE-A-MATIC CONTROL ADJUSTMENTS

See figure 30.

Proper choke and stop switch operation is dependent upon proper adjustment of remote controls on the powered equipment.

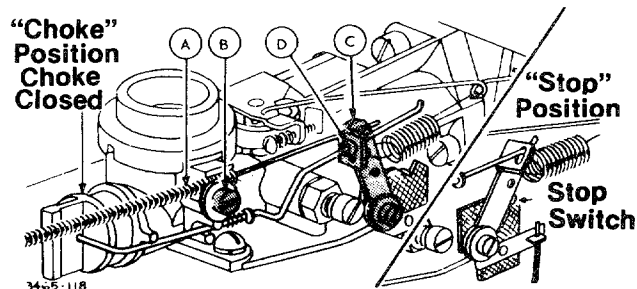


FIGURE 30.

### To Check Operation :

Remove Air Cleaner. Move remote control lever to CHOKE position. The carburetor choke should then be closed. Move the remote control lever to STOP. Speed lever on carburetor should then make good contact with stop switch to short out ignition.

### To Adjust: See figure 31.

Place remote control lever on equipment in FAST (high speed) position. Loosen control casing clamp screw (B) on carburetor. Move control casing (A) and wire forward or backward until speed lever (C) just touches the choke operating link at (D): Tighten casing clamp screw (B) on carburetor.

Recheck operation of controls after adjustment. Replace air cleaner.

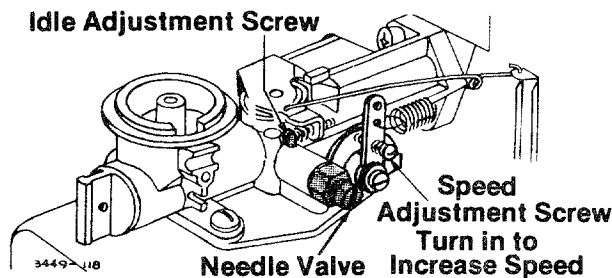


FIGURE 31.

### SPARK PLUG :

1. Remove the spark each time you change the oil and inspect it. See figure 32.
  - A. The electrodes should be kept clean and free OF CARBON. The presence of carbon or excess oil will greatly deter proper engine performance.
  - B. If possible, check the spark plug gap (area between electrodes) using a wire feeler gauge. This specification should be .030.
2. If you need a spark plug refer to the parts list for the proper replacement spark plug.

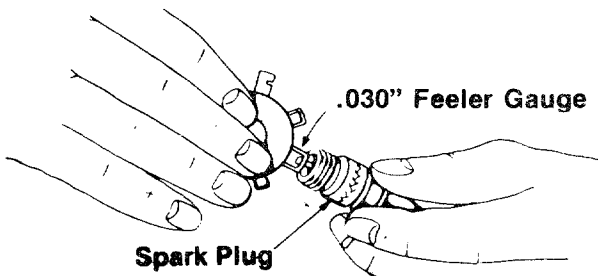


FIGURE 32.

### ADJUSTMENT OF THROTTLE CONTROL CABLE

1. Place the throttle control lever in stop position.

2. Loosen the casing clamp screw and move the throttle control wire in as far as possible.
3. Tighten the casing clamp screw. See figure 33.

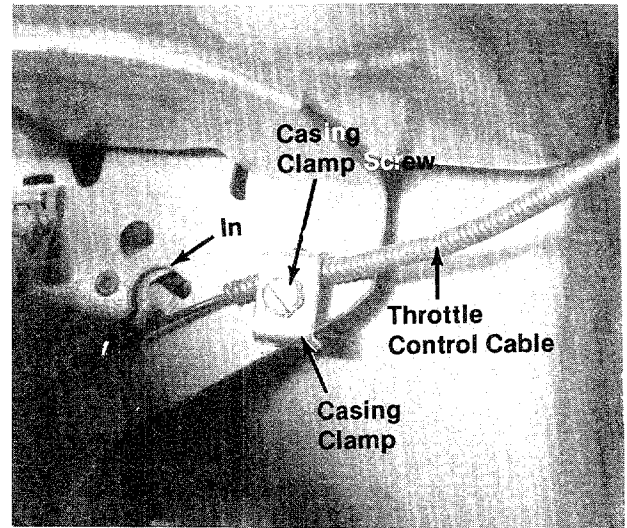


FIGURE 33.

### STORAGE :

If the tiller is not to be used for a while, the following procedure should be followed. The tines, drag stake, transmission, and wheels should be cleaned of all dirt. It is very important that the unit be stored in a level position to prevent engine oil from draining into the cylinder head cavity.

Engines on tillers to be stored between season should be completely drained of fuel to prevent gum deposits forming on essential carburetor parts, and fuel tank.

- (a) All fuel should be removed from fuel tank. Run the engine until it stops from lack of fuel. The small amount of fuel that remains in the sump of the tank should then be removed by absorbing it with a clean dry cloth.
- (b) Clean dirt and chaff from cylinder, cylinder head fins and blower housing.
- (c) Remove spark plug, pour 1 ounce (2 or 3 tablespoons) of S.A.E.-30 oil into cylinder and pull crank cord out slowly to distribute oil. Replace spark plug.

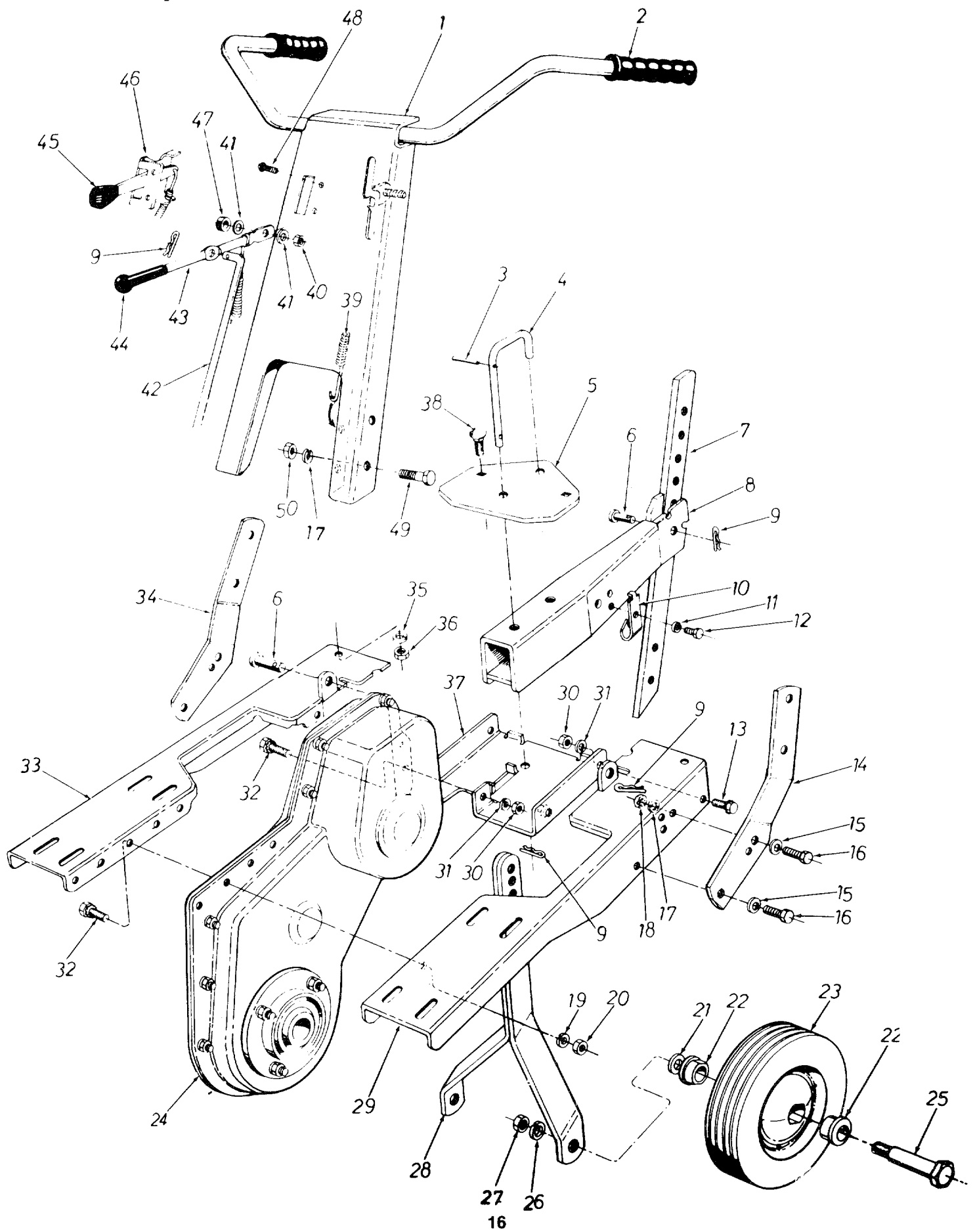
Just as your automobile needs professional mechanical maintenance from time to time, so does your air cooled engine. Cleaning and adjusting of the carburetor and periodic replacement of the spark plug and ignition points is made necessary by NORMAL use.

Professional Air Cooled Engine Service is as close as your nearest SEARS SERVICE DEPARTMENT.

A yearly check-up or tune-up by Sears is a good idea to avoid breakdowns or delay ... do it at the end of the season, then you're ready for the next.



# Repair Parts 3-H.P. Tiller Model 247.297730



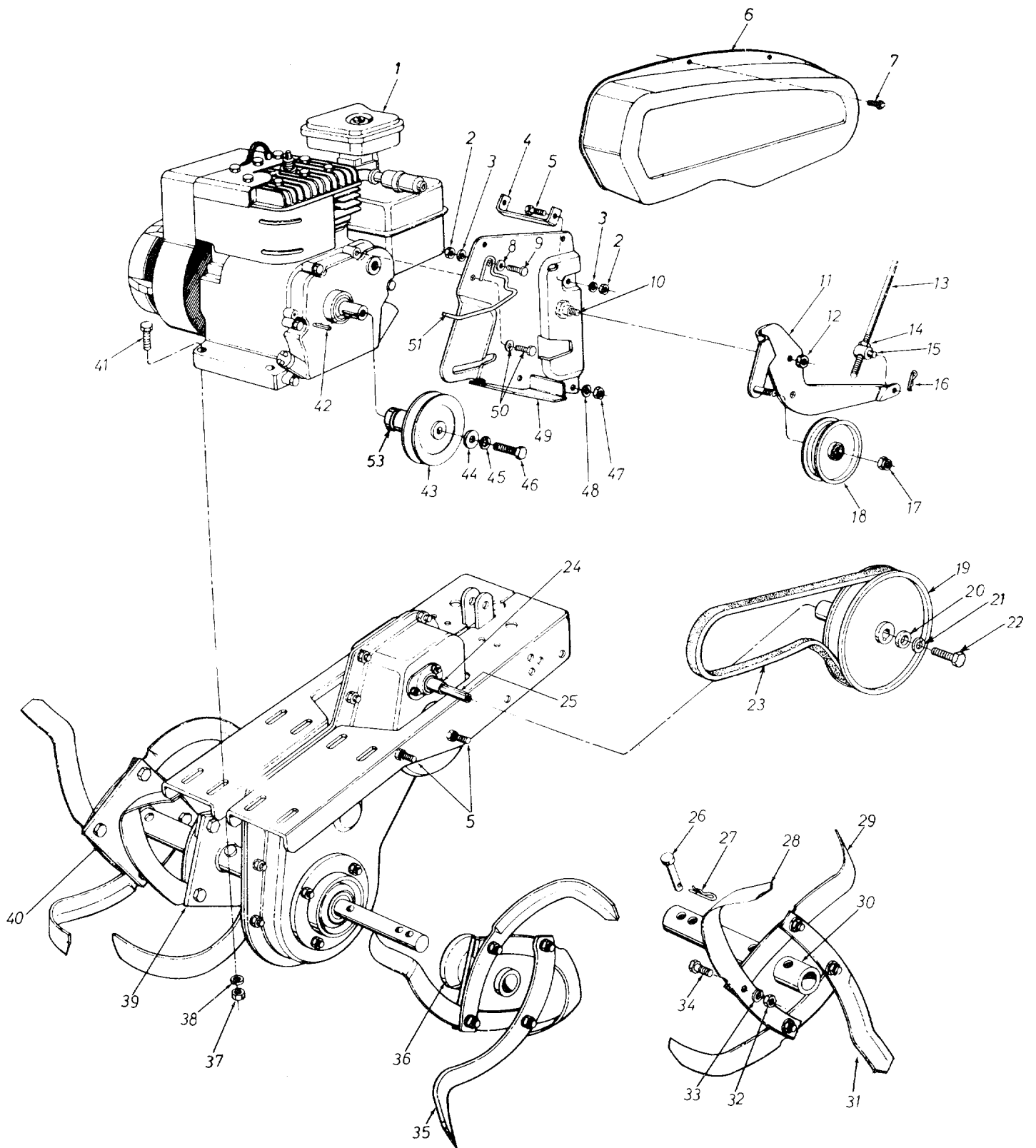
# Repair Parts 3-H.P. Tiller Model 247.297730

| REF. NO. | PART NO.  | DESCRIPTION                              | REF. NO. | PART NO.  | DESCRIPTION                                  |
|----------|-----------|--|----------|-----------|--|
| 1        | 04777—494 | Handle Assembly                          | 27       | 712-0239  | Hex Cent. L-Nut 1/2-20 Thd                   |
| 2        | 01166     | Grip                                     | 28       | 06813—494 | Wheel Bracket Ass'y.                         |
| 3        | 715-0119  | Spring Pin Roll 5/32" Dia.<br>x 1.12 Lg. | 29       | 06792—494 | Engine "U"-Channel Ass<br>—L.H.              |
| 4        | 04602     | "U"-Clevis Pin .500" Dia.                | 30       | 712-0267  | Hex Nut 5/16-18 Thd.*                        |
| 5        | 04586—494 | "U"-Channel Plate                        | 31       | 736-0119  | L-Wash. 5/16" Scr.*                          |
| 6        | 711-0599  | Clevis Pin                               | 32       | 710-0322  | Hex Sems Scr. 5/16-1<br>. 1.00" Lg.*         |
| 7        | 06811     | Drag Stake                               | 33       | 06794—494 | Engine "U"-Channel Ass'y.<br>—R.H.           |
| 8        | 06807—494 | Drag Stake Support Ass'y.                | 34       | 06806—494 | Handle Bracket—R.H.                          |
| 9        | 714-0145  | Internal Cotter Pin 1/2" Dia.            | 35       | 712-0267  | Hex Nut 5/16-18 Thd.*                        |
| 10       | 732-0322  | Drag Stake Spring                        | 36       | 736-0119  | L-Wash. 5/16" Scr.*                          |
| 11       | 736-0329  | L-Wash. 1/4" Scr.*                       | 37       | 06816—494 | "U"-Channel Bracket Ass'y.                   |
| 12       | 710-0599  | Thread Rolling Scr. 1/4-20<br>x .50" Lg. | 38       | 710-0451  | Carriage Bolt 5/16-18 x<br>.75" Lg.*         |
| 13       | 710-0198  | Hex Sems Scr. 5/16-18 x<br>.75" Lg.*     | 39       | 732-0191  | Extension Spring                             |
| 14       | 06805—494 | Handle Bracket—L.H.                      | 40       | 712-0158  | Hex Cent. L-Nut 5/16-18<br>Thd.              |
| 15       | 736-0105  | Belleville Wash. 3/8" I.D.               | 41       | 736-0159  | Fl-Wash. .344" I.D. x .87"<br>O.D.           |
| 16       | 710-0152  | Hex Scr. 3/8-24 x 1.00" Lg.*             | 42       | 747-0183  | Control Rod                                  |
| 17       | 736-0169  | L-Wash. 3/8" Scr.*                       | 43       | 747-0182  | Clutch Lever                                 |
| 18       | 712-0241  | Hex Nut 3/8-24 Thd.*                     | 44       | 720-0143  | Grip   |
| 19       | 736-0119  | L-Wash. 5/16" Scr.*                      | 45       | 07470     | Knob   |
| 20       | 712-0267  | Hex Nut 5/16-18 Thd.*                    | 46       | 746-0272  | Throttle Control Complete                    |
| 21       | 736-0253  | Belleville Wash.                         | 47       | 735-0126  | Rubber Washer                                |
| 22       | 741-0116  | Flange Bearings w/Flats<br>.631 I.D.     | 48       | 710-0160  | Hex Wash. Hd. AB Tapp.<br>Scr. #8 x .62" Lg. |
| 23       | 734-0585  | Wheel Ass'y. 10.0 x 1.750                | 49       | 710-0253  | Hex Scr. 3/8-16 x 1.00" Lg.*                 |
| 24       | 04699     | Transmission Complete                    | 50       | 712-0798  | Hex Nut 3/8-16 Thd.*                         |
| 25       | 738-0318  | Shoulder Scr. .625" Dia. x<br>2.75" Lg.  |          |           |  |
| 26       | 736-0921  | L-Wash. 1/2" Scr.*                       |          |           |  |
|          |           |  | †        | 770-6993  | Owner's Manual                               |

\*Standard Hardware Items—May Be Purchased Locally.

†Not Illustrated

# Repair Parts 3-H.P. Tiller Model 247.297730



# Repair Parts 3-H.P. Tiller Model 247.297730

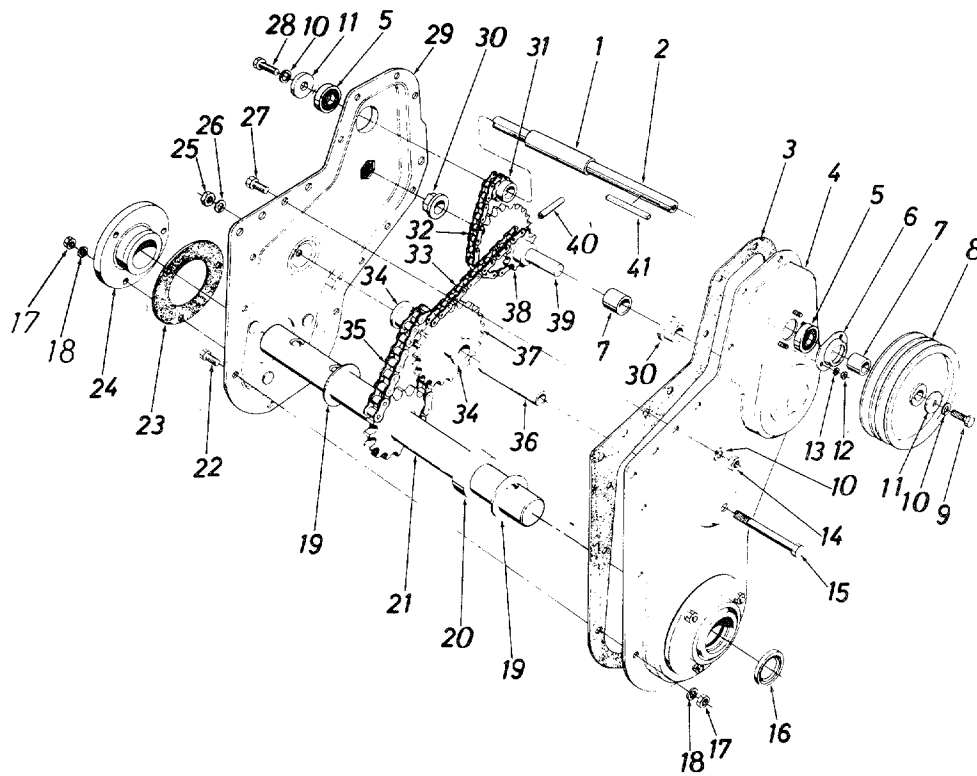
| REF. NO. | PART NO.  | DESCRIPTION                                   | REF. NO. | PART NO. | DESCRIPTION                        |
|----------|-----------|---|----------|----------|------------------------------------|
| 1        | 752-0570  | Engine 3 H.P. B. & S.<br>80202-0659-02        | 27       | 714-0145 | Int. Cotter Pin 1/2" Dia.          |
| 2        | 712-0287  | Hex Nut 1/4-20 Thd.*                          | 28       | 742-0179 | 12" Tine Only—L.H.                 |
| 3        | 736-0329  | L-Wash. 1/4" Scr.*                            | 29       | 742-0180 | 12" Tine Only—R.H.                 |
| 4        | 06801     | Support Brkt.                                 | 30       | 04683    | Outer Tine Adapter Ass'y.          |
| 5        | 710-0252  | Hex Scr. 1/4-20 x .75" Lg.*                   | 31       | 04745    | Outer Tine Ass'y. Comp.—<br>L.H.   |
| 6        | 06796—493 | Belt Guard                                    | 32       | 712-0241 | Hex Nut 3/8-24 Thd.*               |
| 7        | 710-0599  | Thd. Rolling Scr. 1/4-20 x<br>.50" Lg.        | 33       | 736-0169 | L-Wash. 3/8" Scr.*                 |
| 8        | 736-0463  | FI-Wash. 1/4" I.D.                            | 34       | 710-0191 | Hex Scr. 3/8-24 x 1.25" Lg.*       |
| 9        | 710-0252  | Hex Scr. 1/4-20 x .75" Lg.*                   | 35       | 04743    | Inner Tine Ass'y. Comp.—<br>L.H.   |
| 10       | 736-0281  | Shld. Bolt .625 Dia. x .170"<br>Lg.           | 36       | 04673    | Inner Tine Adapter Ass'y.          |
| 11       | 06784     | Forward Idler Brkt. Ass'y.                    | 37       | 712-0267 | Hex Nut 5/16-18 Thd.*              |
| 12       | 712-0375  | Hex Cent. L-Nut 3/8-16 Thd.                   | 38       | 712-0170 | Shakeproof Washer                  |
| 13       | 747-0183  | Clutch Control Rod                            | 39       | 04742    | Inner Tine Ass'y. Comp.—<br>R.H.   |
| 14       | 712-0195  | Speed Nut 3/8-24 Thd.                         | 40       | 04744    | Outer Tine Ass'y. Comp.—<br>R.H.   |
| 15       | 711-0392  | Ferrule                                       | 41       | 710-0442 | Hex Scr. 5/16-18 x 1.50" Lg.*      |
| 16       | 714-0145  | Int. Cotter Pin 1/2" Dia.                     | 42       | 714-0133 | Sq. Key 3/16 x 1.50" Lg.*          |
| 17       | 712-0262  | Hex Jam Nut 3/8-24 Thd.                       | 43       | 756-0265 | Engine Pulley                      |
| 18       | 756-0225  | FI-Idler w/ Flanges 3.12 O.D.<br>x .75        | 44       | 736-0258 | FI-Wash. 3/8" I.D. x 1.00"<br>O.D. |
| 19       | 756-0264  | Chain Case Pulley 6.0" Dia.                   | 45       | 736-0169 | L-Wash. 3/8" Scr.*                 |
| 20       | 736-0231  | FI-Wash. 5/16" I.D. x 1.120"<br>O.D.          | 46       | 710-0191 | Hex Scr. 3/8-24 x 1.25" Lg.*       |
| 21       | 736-0170  | Shake-Proof Washer                            | 47       | 712-0287 | Hex Nut 1/4-20 Thd.*               |
| 22       | 710-0643  | Hex Scr. 5/16-18 x 1.00" Lg.<br>Spec.         | 48       | 736-0329 | L-Wash. 1/4" Scr.*                 |
| 23       | 754-0154  | "V"-Belt 1/2" x 37" Lg.                       | 49       | 06803    | Clutch Mtg. Plate                  |
| 24       | 750-0229  | Spacer .635" I.D. x .88" O.D.<br>x 1.035" Lg. | 50       | —        | Part of Engine                     |
| 25       | 714-0133  | Sq. Key 3/16 x 1.50" Lg.*                     | 51       | 747-0181 | Belt Guard Rod                     |
| 26       | 711-0599  | Clevis Pin                                    | 53       | 750-0236 | Spacer .763" I.D. x 1.100"<br>O.D. |

\*Standard Hardware Items—May Be Purchased Locally.

| TILLER ACCESSORIES   |  |
|--|--|
| Til-Row Attachment<br>Leveling/Snow-Blade Kit<br>V-Bar Cultivating Kit<br>Drag Stake Cultivating Kit<br>V-Bar Frame<br>4-Pt. Cultivator Tines<br>Hiller/Furrower<br>Depth Gauge Wheels<br>6-Tang Universal Cult.<br>Drag Stake | 8" Furrower<br>15" Sweep Cult./Hoe<br>32" Leveling Rake<br>Cultivating Shields<br>32" Leveling/Snow-Blade<br>13 x 5.00—6 Pneu. Traction Tires<br>Wheel Weights<br>Tire Chains (pr.)<br>Wheel Weights F/Leveling Snow-Blade |

THESE ACCESSORIES ARE AVAILABLE IN THE SEARS BIG SPRING CATALOG.

# Repair Parts 3-H.P. Tiller Model 247.297730



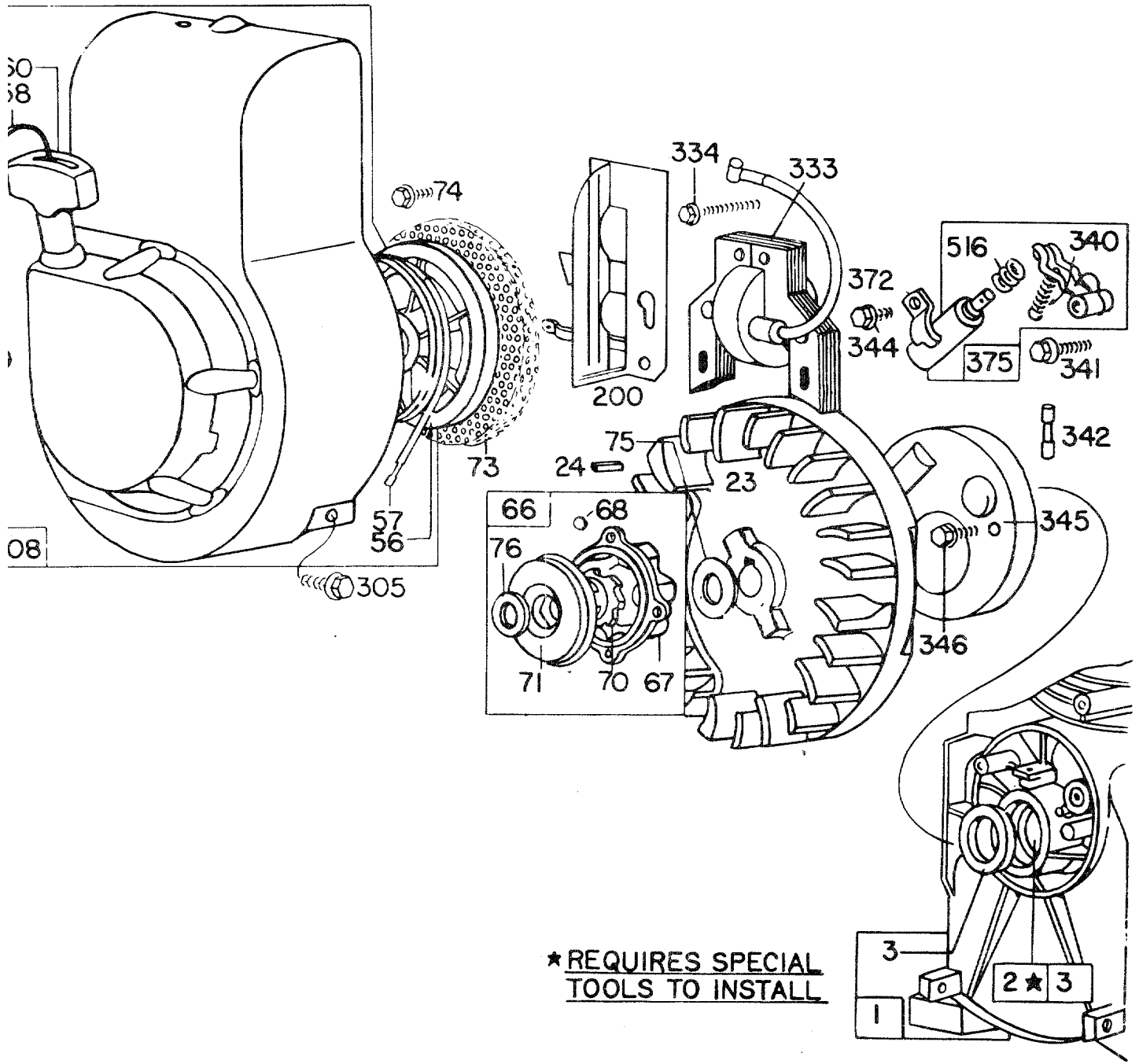
## Repair Parts Transmission 04699

| REF. NO. | PART NO. | DESCRIPTION                            | REF. NO. | PART NO. | DESCRIPTION                             |
|----------|----------|--|----------|----------|---|
| 1        | 750-0315 | Spacer .657 I.D. x .78 O.D. x 2.19     | 22       | 710-0195 | Hex Scr. 1/4-28 x .62" Lg.*             |
| 2        | 738-0182 | Jack Shaft                             | 23       | 721-0133 | Gasket for Bearing Hsg.                 |
| 3        | 721-0132 | Gasket for Housing                     | 24       | 741-0198 | Bearing Housing Ass'y.                  |
| 4        | 06790    | Housing Half—L.H.                      | 25       | 712-0798 | Hex Nut 3/8-16 Thd.*                    |
| 5        | 741-0155 | Ball Bearing .625 I.D. x 1.375 O.D.    | 26       | 736-0169 | L-Wash. 3/8" Scr.*                      |
| 6        | 05034    | Bearing Housing                        | 27       | 710-0322 | Hex Sems Scr. 5/16-18 x 1.00" Lg.*      |
| 7        | 750-0229 | Spacer .625 I.D. x .88 O.D. x 1.035    | 28       | 710-0538 | Hex Scr. 5/16-18 x .62" Lg. Special     |
| 8        | 756-0262 | Chain Case Pulley 6.00" Dia.           | 29       | 06788    | Housing Half—R.H.                       |
| 9        | 710-0643 | Hex Scr. 5/16-18 x 1.00" Lg. Special   | 30       | 748-0229 | Hex Flanged Bearing .630 I.D.           |
| 10       | 736-0119 | L-Wash. 5/16" Scr.*                    | 31       | 713-0206 | Sprocket 10 Teeth x .500 Pitch          |
| 11       | 736-0231 | Fl-Wash. 5/16 I.D. x 1.125 O.D. x .125 | 32       | 713-0131 | #41 Chain 1/2" Pitch x 33 Links Endless |
| 12       | 712-0287 | Hex Nut 1/4-20 Thd.*                   | 33       | 713-0186 | #42 Chain 1/2" Pitch x 48 Links Endless |
| 13       | 736-0329 | L-Wash. 1/4" Scr.*                     | 34       | 748-0855 | Flange Bearing .628 I.D.                |
| 14       | 712-0267 | Hex Nut 5/16-18 Thd.*                  | 35       | 713-0187 | #50 Chain 5/8" Pitch x 28 Links Endless |
| 15       | 710-0644 | Hex Scr. 3/8-16 x 3.25" Lg.            | 36       | 738-0320 | Sprocket Shaft                          |
| 16       | 721-0102 | Oil Seal 1" I.D. x 1.357 O.D.          | 37       | 713-0182 | Sprocket Bearing Sleeve Ass'y.          |
| 17       | 712-0138 | Hex Nut 1/4-28 Thd.*                   | 38       | 713-0181 | Sprocket Sleeve Ass'y.                  |
| 18       | 736-0329 | L-Wash. 1/4" Scr.*                     | 39       | 738-0308 | Sprocket Shaft                          |
| 19       | 736-0259 | Fl-Wash. 1.0" I.D. x 1.62 O.D. x .090  | 40       | 715-0114 | Spring Pin Spiral 1/4" Dia. x 1.5" Lg.  |
| 20       | 750-0314 | Spacer 1.0" I.D. x 2.0" O.D. x .68     | 41       | 714-0133 | Sq. Key 3/16 x 1.50" Lg.                |
| 21       | 06800    | Tine Shaft Ass'y.                      |          |          |   |

\*Standard Hardware Items—  
May Be Purchased Locally.

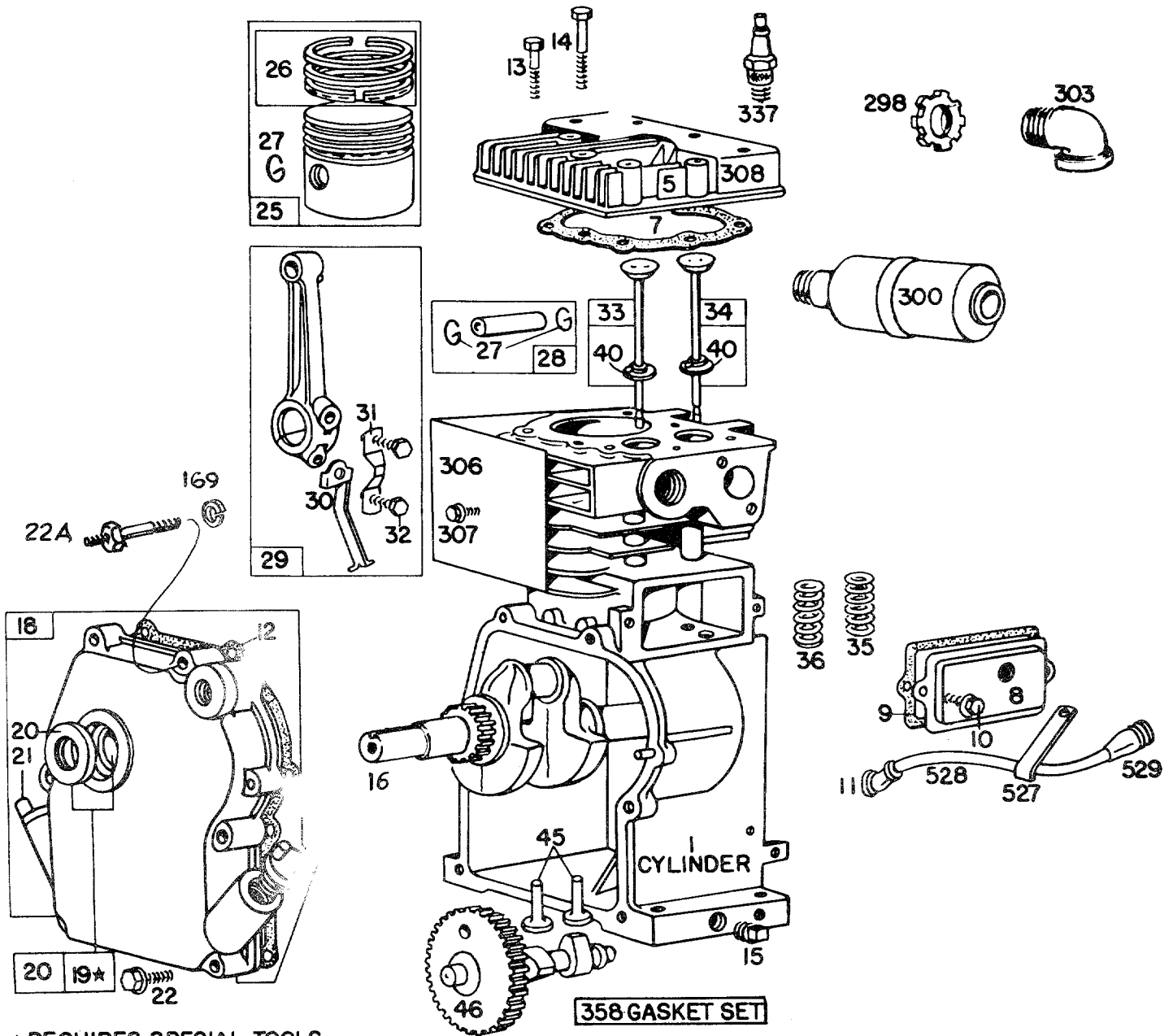
# Repair Parts

3-H.P. CHAIN DRIVE TILLER MODEL 247.297730  
ENGINE MODEL 80202 TYPE 0659-02



# Repair Parts

3-H.P. CHAIN DRIVE TILLER MODEL 247.297730  
 ENGINE MODEL 80202 TYPE 0659-02

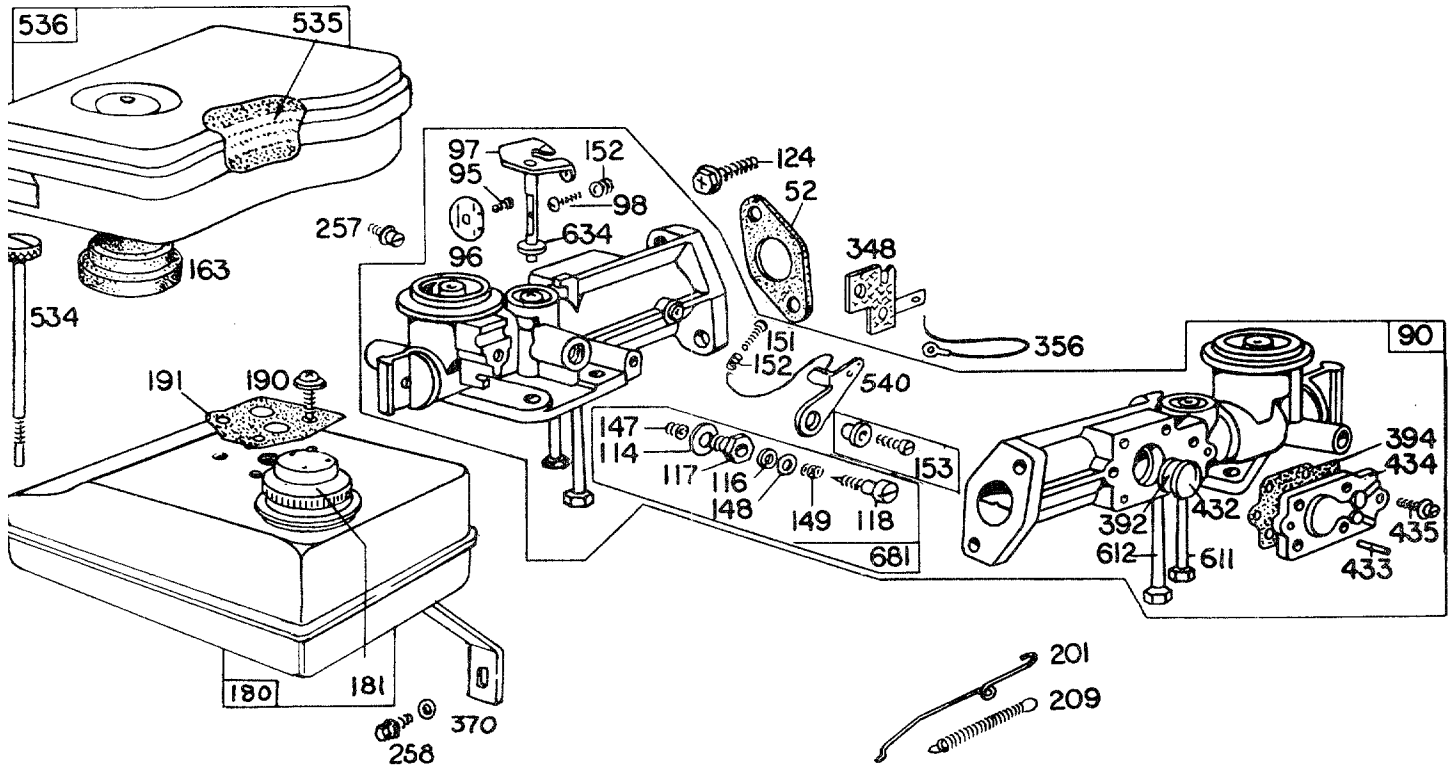


**\*REQUIRES SPECIAL TOOLS  
 TO INSTALL**



# Repair Parts

3-H.P. CHAIN DRIVE TILLER MODEL 247.297730  
ENGINE MODEL 80202 TYPE 0659-02



# Repair Parts

3-H.P. CHAIN DRIVE TILLER MODEL 247.297730  
ENGINE MODEL 80202 TYPE 0659-02

| REF. NO. | PART NO. | DESCRIPTION  | REF. NO. | PART NO. | DESCRIPTION   |
|----------|----------|--|----------|----------|---|
| 1        | 296561   | Cylinder Ass'y.  |          | 294226   | Ring Set—.030" O.S. Piston  |
| 2        | 293708   | Bushing—Cylinder<br><b>Note:</b> Requires special tools for installation.  |          |          | Consists of:<br>210496 Ring, Piston, Compression, Top, .030" O.S.<br>210495 Ring, Piston, Compression, Center, .030" O.S.<br>210497 Ring, Piston, Oil, .030" O.S. |
| 3        | 89660    | Seal—Oil   |          |          |   |
| 5        | 210812   | Head—Cylinder  |          |          |   |
| 7        | *27670   | Gasket—Cylinder Head   |          |          |   |
| 8        | 294178   | Breather—Valve Chamber   |          |          |   |
| 9        | *27549   | Gasket—Valve Cover   | 27       | 26026    | Lock—Piston Pin   |
| 10       | 93394    | Screw—Breather Mtg. Sem  | 28       | 298909   | Pin Ass'y.—Piston—Std.  |
| 11       | 66578    | Grommet—Breather Tube  |          | 298908   | Pin Ass'y.—Piston—.005" O.S.  |
| 12       | *27586   | Gasket—Crankcase—.015" thick (Standard)  | 29       | 294367   | Rod Ass'y.—Connecting<br><b>Note:</b> For Connecting Rod with .020" undersize Crankpin Bore—order No. 296079.   |
|          | *27617   | Gasket—Crankcase—.005" thick   |          |          |   |
|          | *27618   | Gasket—Crankcase—.009" thick   |          |          |   |
| 13       | 93111    | Screw—Cylinder Head (1-15/16" long)  | 30       | 220670   | Dipper—Connecting Rod   |
| 14       | 93113    | Screw—Cylinder Head (2-5/16" long)   | 31       | 220756   | Lock—Connecting Rod Screw   |
| 15       | 91249    | Plug—Pipe, 1/4" Std., Sq. Hd.  | 32       | 92296    | Screw—Connecting Rod  |
| 16       | 261298   | Crankshaft   | 33       | 296676   | Valve—Exhaust   |
| 18       | 294305   | Cover Ass'y.—Crankcase   | 34       | 296677   | Valve—Intake  |
| 19       | 293708   | Bushing—Crankcase Cover<br><b>Note:</b> 293708 Bushings require special tools for installation.  | 35       | 260552   | Spring—Intake Valve   |
| 20       | 89660    | Seal—Oil   | 36       | 26478    | Spring—Exhaust Valve  |
| 21       | 66768    | Plug—Oil Filler  | 37       | 220971   | Guard—Flywheel  |
| 22       | 93032    | Screw—Crankcase Cover Mtg. Sem   | 40       | 93312    | Retainer—Valve Spring   |
| 22A      | 93656    | Stud   | 45       | 230173   | Tappet—Valve  |
| 23       | 296884   | Flywheel—Magneto   | 46       | 210453   | Gear—Cam  |
| 24       | 61760    | Key—Flywheel   | 52       | *27355   | Gasket—Intake Elbow Mtg. (2 used)   |
| 25       | 295587   | Piston Ass'y.—Std.   | 56       | 280117   | Pulley—Rewind Starter   |
|          | 295588   | Piston Ass'y.—.010" O.S.   | 57       | 294303   | Spring—Rewind Starter   |
|          | 295589   | Piston Ass'y.—.020" O.S.   | 58       | 66694    | Rope—Starter  |
|          | 295590   | Piston Ass'y.—.030" O.S.   | 59       | 230228   | Pin—Starter Grip  |
|          |          | <b>RING SETS:</b>  | 60       | 66728    | Grip—Starter Rope   |
|          |          | <b>Note:</b> For Chrome Piston Ring Set—standard size—order Part No. 297201.   | 66       | 298310   | Clutch Ass'y.—Rewind Starter  |
| 26       | 294232   | Ring Set—Std. Piston, Consists of:<br>210471 Ring, Piston, Compression, Top<br>210472 Ring, Piston, Compression, Center<br>210473 Ring, Piston, Oil  | 67       | 211383   | Housing—Starter Clutch  |
|          | 294224   | Ring Set—.010" O.S. Piston Consists of:<br>210490 Ring, Piston, Compression, Top, .010" O.S.<br>210489 Ring, Piston, Compression, Center, .010" O.S.<br>210491 Ring, Piston, Oil, .010" O.S. | 68       | 63770    | Ball—Clutch   |
|          | 294225   | Ring Set—.020" O.S. Piston Consists of:<br>210493 Ring, Piston, Compression, Top, .020" O.S.<br>210492 Ring, Piston, Compression, Center, .020" O.S.<br>210494 Ring, Piston, Oil, .020" O.S. | 70       | 298436   | Ratchet—Rewind Starter  |
|          |          |  | 71       | 221653   | Washer—Clutch Retainer  |
|          |          |  | 73       | 221661   | Screen—Rotating   |
|          |          |  | 74       | 93490    | Screw—Rotating Screen Mtg. Sem  |
|          |          |  | 75       | 220865   | Washer—Spring   |
|          |          |  | 76       | 68238    | Washer—Ratchet Sealing  |
|          |          |  | 90       | 391773   | Carburetor Ass'y.   |
|          |          |  | 95       | 93499    | Screw—Throttle Valve Mtg. Sem   |
|          |          |  | 96       | 211203   | Valve—Throttle  |
|          |          |  | 97       | 297961   | Shaft and Lever—Throttle  |
|          |          |  | 98       | 93524    | Screw—Machine, Rd. Hd.—5-40 x 1/2"  |
|          |          |  | 114      | 66594    | Gasket—Needle Valve Nut   |
|          |          |  | 116      | 65978    | Packing—Needle Valve  |
|          |          |  | 117      | 230590   | Nut—Needle Valve  |
|          |          |  | 118      | 23433    | Valve—Needle  |
|          |          |  | 124      | 93357    | Screw—Hex Hd.   |
|          |          |  | 147      | 230591   | Seat—Needle Valve   |
|          |          |  | 148      | 22235    | Washer—Needle Valve (2)   |
|          |          |  | 149      | 26336    | Spring—Needle Valve   |
|          |          |  | 151      | 93350    | Screw—Mach., Rd. Hd. 5-40 x 3/4"  |
|          |          |  | 152      | 280575   | Spring—Speed and Throttle Adj.  |
|          |          |  | 153      | 298031   | Screw—Carburetor Cam and Lever  |
|          |          |  | 163      | *27660   | Gasket—Air Cleaner Mounting   |
|          |          |  | 169      | 90832    | Washer—Lock—1/4 x 3/32 x 5/64"  |

# Repair Parts

3-H.P. CHAIN DRIVE TILLER MODEL 247.297730  
ENGINE MODEL 80202 TYPE 0659-02

| REF. NO. | PART NO. | DESCRIPTION   |
|----------|----------|---|
| 180      | 299817   | Tank Ass'y.—Fuel  |
| 181      | 298425   | Cap—Fuel Tank   |
| 190      | 93341    | Screw—Fuel Tank Mtg. Sem  |
| 191      | *27911   | Gasket—Fuel Tank Mounting   |
| 200      | 297310   | Blade—Governor  |
| 201      | 260898   | Link—Governor   |
| 209      | 260041   | Spring—Air Vane Gov.  |
| 257      | 93263    | Screw—Fil Hd., 10-32 x 3/8"   |
| 258      | 93062    | Screw—Sem   |
| 298      | 220859   | Locknut   |
| 300      | 89966    | Muffler—Exhaust   |
| 303      | 91943    | Elbow—Exhaust   |
| 305      | 93158    | Screw—Sem   |
| 306      | 220478   | Shield—Cylinder   |
| 307      | 93042    | Screw—Cylinder Shield Mtg. Sem  |
| 308      | 220581   | Cover—Cylinder Head   |
| 333      | 298502   | Armature—Magneto  |
| 334      | 93381    | Screw—Armature Mtg. Sem   |
| 337      | 298809   | Plug—Spark (with gasket)<br><b>Note:</b> Spark Plugs 298809 use Ignition Cable Terminal No. 221798.                             |
| 340      | 26018    | Spring—Breaker Arm  |
| 341      | 93381    | Screw—Sem   |
| 342      | 65704    | Plunger—Breaker Point   |
| 344      | 93042    | Screw—Condenser Clamp Mtg. Sem  |
| 345      | 220366   | Cover—Breaker Point and Condenser   |
| 346      | 93014    | Screw—Dust Cover Mounting   |
| 348      | 296110   | Plate Ass'y.—Stop Switch Insulator  |
| 356      | 391115   | Wire—Ground   |
| 358      | 297275   | Gasket Set  |
| 370      | 66432    | Washer—Plain  |
| 372      | 220477   | Clamp—Condenser   |
| 375      | 294628   | Breaker Points and Condenser Set<br><b>Note:</b> 299061 Ignition Kit Includes 294628 Point Set 65704 Plunger 61760 Key—Flywheel |
| 392      | 260455   | Spring—Fuel Pump Diaphragm  |
| 394      | 270026   | Diaphragm   |
| 432      | 221377   | Cap—Spring  |
| 433      | 93265    | Pin—Diaphragm Cover   |
| 434      | 210959   | Cover—Diaphragm   |
| 435      | 93141    | Screw—Diaphragm Cover   |
| 516      | 260374   | Spring—Connector  |
| 527      | 221279   | Clamp—Breather Tube   |
| 528      | 230634   | Tube—Breather   |
| 529      | 67608    | Grommet—Breather Tube   |
| 534      | 93322    | Screw—Air Cleaner   |
| 535      | 27987    | Element—Air Cleaner   |
| 536      | 296766   | Cleaner Ass'y.—Air  |
| 540      | 220678   | Lever—Speed Adjuster  |
| 608      | 294259   | Starter Ass'y.—Rewind   |
| 611      | 297219   | Pipe—Fuel (2-5/8" long) Plastic   |
| 612      | 296811   | Pipe—Fuel (1-5/8" long) Plastic   |
| 634      | 270167   | Washer—Throttle Shaft   |
| 681      | 299060   | Needle Valve Kit  |

\*Included in Gasket Set—Part No. 297275.





**Sears**

**owners  
manual**

**MODEL NO.  
247.297730**

**Sears  
SERVICE  
is at  
Your  
SERVICE**

## **HOW TO ORDER REPAIR PARTS**

The Model Number will be found stamped on a plate attached to the chassis. Always mention the Model Number when requesting service or repair parts for your tiller.

All parts listed herein may be ordered through SEARS ROEBUCK AND CO. or SIMPSON SEARS LIMITED RETAIL or CATALOG STORE.

WHEN ORDERING REPAIR PARTS, ALWAYS GIVE THE FOLLOWING INFORMATION AS SHOWN IN THIS LIST.

1. The PART NUMBER
2. The MODEL NUMBER 247.297730
3. The PART DESCRIPTION
4. The NAME OF MERCHANDISE — Tiller

If the parts you need are not stocked locally, your order will be electronically transmitted to a Sears Repair Parts Distribution Center for expedited handling.

Your Sears merchandise takes on added value when you discover that Sears has over 2,000 Service Units throughout the country. Each is staffed by Sears-trained, professional technicians.

**SEARS, ROEBUCK AND CO., Chicago, Ill. 60684 U.S.A.  
and SIMPSONS-SEARS LIMITED, Toronto, Canada**